



# 950

Nominal Diameter	<b>5" / 13cm</b>
Rated Impedance	<b>8 Ω</b>
Half space sensitivity (1W@1m)	<b>94 dB SPL</b>
Power Handling Capacity	<b>80 W AES</b>
SPL max (continuous)	<b>109 dB SPL</b>
Usable frequency range	<b>300 - 4000 Hz</b>
Speaker net mass	<b>2.02 kg</b>

## 5 inches midrange driver



### Architecture Highlights

- Noiseless natural convection Intercooling System
- Ferrite magnet system with symmetric BL(x) and Le(x)
- High definition CCAR vented voice coil
- Critical damping flat foam surround
- Lightweight basket

### Motor architecture

Magnet material	-	<b>Fe</b>
Voice coil diameter	mm	<b>38</b>
Voice coil length	mm	<b>7.5</b>
Air gap height	mm	<b>6</b>

### Typical characteristics

Rated impedance	Z	Ω	<b>8</b>
Half space sensitivity (1W@1m)	-	dB SPL	<b>94.0</b>
Usable freq. range	-	HZ	<b>300 - 4000</b>
Power handling capacity (AES)	-	W	<b>80</b>
Max Sound Pressure Level	SPLmax	dB SPL	<b>109</b>
Min. impedance modulus	Zmin	Ω@Hz	<b>6.1@800</b>
Voice-coil inductance @ 1kHz	Le1k	mH	<b>0.599</b>
Voice-coil inductance @ 10kHz	Le10k	mH	<b>0.235</b>
BL product	BL	N/A	<b>8.8</b>
Moving mass	Mms	kg	<b>0.0081</b>

### Thiele-Small parameters

Resonance frequency	Fs	Hz	<b>200 (±)</b>
DC Resistance	Re	Ω	<b>5.3 (±0.5)</b>
Mechanical quality factor	Qms	1	<b>5.99</b>
Electrical quality factor	Qes	1	<b>0.70</b>
Total quality factor	Qts	1	<b>0.62</b>
Suspension compliance	Cms	10 <sup>-6</sup> .m/N	<b>80</b>
Effective piston area	Sd	m <sup>2</sup>	<b>0.0109</b>
Equivalent Cas air load	Vas	m <sup>3</sup>	<b>0.0013</b>
Max linear excursion	Xmax	mm	<b>± 2.5</b>
Linear displacement volume	Vd	10 <sup>-3</sup> .m <sup>3</sup>	<b>0.0273</b>
Reference efficiency	H	%	<b>1.45</b>
Unity load volume	Vas.Qts <sup>2</sup>	10 <sup>-3</sup> .m <sup>3</sup>	<b>0.5</b>

### Absolute maximum ratings

Short term max. input voltage	Vmax	V	<b>50</b>
Max.excursion before damage	Xdam	mm	<b>± 3</b>
Ambient operating temperature	Ta	°C	<b>-10 to +50</b>
Storage temperature		°C	<b>-20 to +70</b>
Environmental withstanding		<b>Humidity proof</b>	

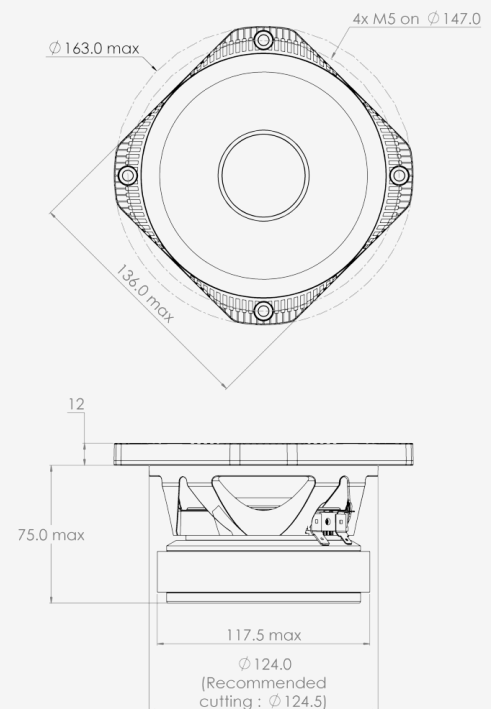

### Application information

Air volume occupied by the driver	10 <sup>-3</sup> .m <sup>3</sup>	<b>0.38</b>
Speaker net mass	kg	<b>2.02</b>
Baffle cut-out diameter (front mounting)	mm	<b>124.5</b>
Bolt number & Metric diameter	-	<b>4x M5</b>
Bolt circle diameter	mm	<b>147.0</b>
Max overall dimension (on ears)	mm	<b>163.0</b>
Max overall dimension (out of ears)	mm	<b>136.0</b>
Flange height	mm	<b>12.5</b>
Max magnet diameter	mm	<b>117.5</b>
Max depth (front mounting)	mm	<b>75.0</b>
Recommended reflex box	Lts / Hz	<b>1.5L sealed</b>
Electrical connection	-	<b>6.35x0.8 + 4.8x0.5</b>

**FASTON**