



950Nd

Nominal Diameter	5" / 13cm
Rated Impedance	8 Ω
Half space sensitivity (1W@1m)	94 dB SPL
Power Handling Capacity	80 W AES
SPL max (continuous)	110 dB SPL
Usable frequency range	300 - 4000 Hz
Speaker net mass	0.98 kg

5 inches midrange driver



Architecture Highlights

- Noiseless natural convection Intercooling System
- Neodymium magnet system with symmetric BL(x) and Le(x)
- High definition CCAR vented voice coil
- Critical damping flat foam surround
- Lightweight basket

Motor architecture

Magnet material	-	Nd
Voice coil diameter	mm	38
Voice coil length	mm	7.5
Air gap height	mm	6

Typical characteristics

Rated impedance	Z	Ω	8
Half space sensitivity (1W@1m)	-	dB SPL	94.0
Usable freq. range	-	HZ	300 - 4000
Power handling capacity (AES)	-	W	80
Max Sound Pressure Level	SPLmax	dB SPL	110
Min. impedance modulus	Zmin	Ω@Hz	6.1@800
Voice-coil inductance @ 1kHz	Le1k	mH	0.576
Voice-coil inductance @ 10kHz	Le10k	mH	0.235
BL product	BL	N/A	8.9
Moving mass	Mms	kg	0.0081

Thiele-Small parameters

Resonance frequency	Fs	Hz	200 (±40)
DC Resistance	Re	Ω	5.4 (±0.5)
Mechanical quality factor	Qms	1	5.99
Electrical quality factor	Qes	1	0.69
Total quality factor	Qts	1	0.62
Suspension compliance	Cms	10 ⁻⁶ .m/N	80
Effective piston area	Sd	m ²	0.0109
Equivalent Cas air load	Vas	m ³	0.0013
Max linear excursion	Xmax	mm	± 2.5
Linear displacement volume	Vd	10 ⁻³ .m ³	0.0273
Reference efficiency	H	%	1.45
Unity load volume	Vas.Qts ²	10 ⁻³ .m ³	0.5

Absolute maximum ratings

Short term max. input voltage	Vmax	V	50
Max.excursion before damage	Xdam	mm	± 3
Ambient operating temperature	Ta	°C	-10 to +50
Storage temperature		°C	-20 to +70
Environmental withstanding		Humidity proof	

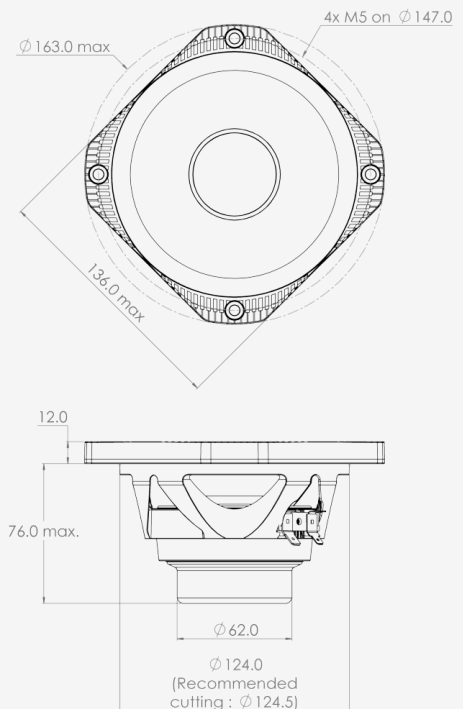

Application information

Air volume occupied by the driver	10 ⁻³ .m ³	0.18
Speaker net mass	kg	0.98
Baffle cut-out diameter (front mounting)	mm	124.5
Bolt number & Metric diameter	-	4x M5
Bolt circle diameter	mm	147.0
Max overall dimension (on ears)	mm	163.0
Max overall dimension (out of ears)	mm	136.0
Flange height	mm	12.5
Max magnet diameter	mm	-
Max depth (front mounting)	mm	76.0
Recommended reflex box	Lts / Hz	1.5L sealed
Electrical connection	-	6.35x0.8 + 4.8x0.5

FASTON