

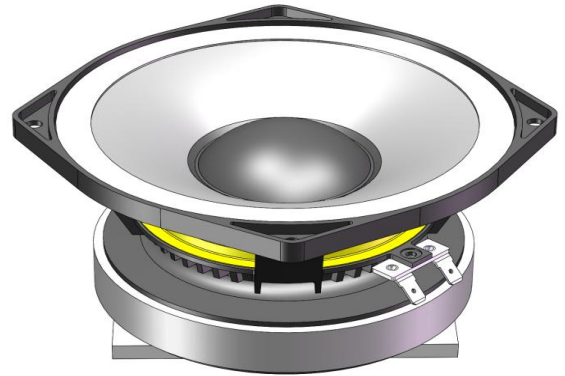

1683-26

Nominal Diameter	6.5" / 17 cm
Rated Impedance	8
Sensitivity	94 dB SPL
Power Handling Capacity	250 W AES
SPL max (continuous)	114 dB SPL
Usable frequency range	300 - 5000 Hz
Speaker net mass	2.8 kg

6.5" midrange driver



Architecture highlights :

- Midrange unit with critical damping diaphragm
- Ultra light CCAR voice coil
- Natural convection Intercooler System
- Coaxial apparatus with 3x M6 on \varnothing 57.2 mm and 2x M6 on \varnothing 76.2 mm

Motor architecture

Magnet material	-	Fe
Voice coil diameter	mm	51
Voice coil length	mm	11
Air gap height	mm	9

Typical characteristics

Rated impedance	Z	Ω	8
Half space sensitivity (1W@1m)	-	dB SPL	94.0
Usable freq. range	-	Hz	300 - 5000
Power handling capacity (AES)	-	W	250
Max Sound Pressure Level	SPL _{max}	dB SPL	114
Min. impedance modulus	Z _{min}	Ω @Hz	6.9@550
Voice-coil inductance @ 1kHz	Le _{1k}	mH	0.599
Voice-coil inductance @ 10kHz	Le _{10k}	mH	0.249
BL product	BL	N/A	12.5
Moving mass	M _{ms}	kg	0.0130

Thiele-Small parameters

Resonance frequency	F _s	Hz	125 (±25)
DC Resistance	Re	Ω	5.3 (±0.5)
Mechanical quality factor	Q _{ms}	1	4.86
Electrical quality factor	Q _{es}	1	0.35
Total quality factor	Q _{ts}	1	0.32
Suspension compliance	C _{ms}	10 ⁻⁶ .m/N	120
Effective piston area	S _d	m ²	0.0129
Equivalent Cas air load	V _{as}	m ³	0.0029
Max linear excursion	X _{max}	mm	± 2.5
Linear displacement volume	V _d	10 ⁻³ .m ³	0.0322
Reference efficiency	η_0	%	1.6
Unity load volume	V _{as} .Q _{ts} ²	10 ⁻³ .m ³	0.3

Absolute maximum ratings

Short term max. input voltage	V _{max}	V	90
Max.excursion before damage	X _{dam}	mm	± 9.0
Ambient operating temperature	T _a	°C	-10 to +50
Storage temperature		°C	-20 to +70
Environmental withstanding			tropical

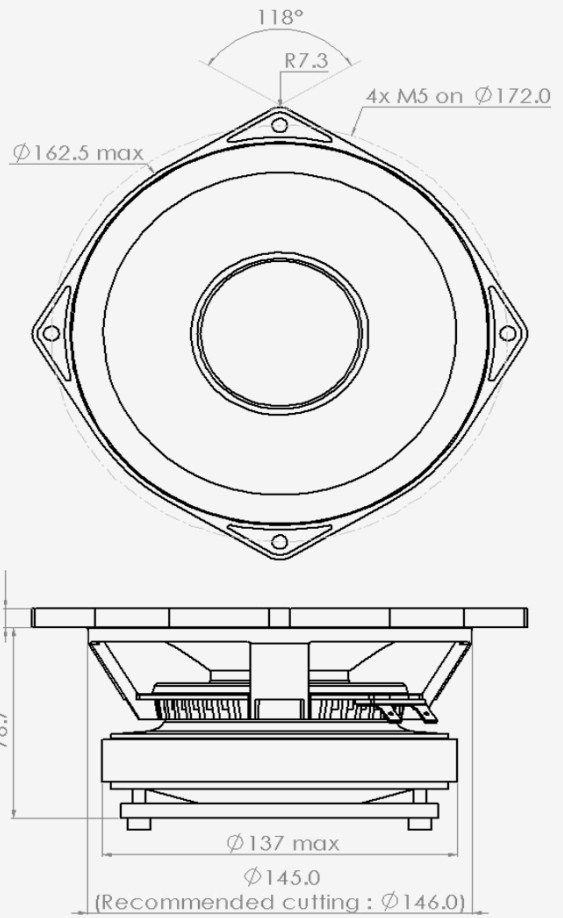

Mounting information

Air volume occupied by the driver	10 ⁻³ .m ³	0.64
Speaker net mass	kg	2.80
Baffle cut-out diameter (front mounting)	mm	146.0
Bolt number & Metric diameter	-	4x M5
Bolt circle diameter	mm	172.0
Max overall dimension (on ears)	mm	187.5
Max overall dimension (out of ears)	mm	162.5
Flange height	mm	8.0
Max magnet diameter	mm	137.0
Max depth (front mounting)	mm	73.5
Recommended reflex box	Lts / Hz	-
Electrical connection		6.35x0.8 FASTON



SPL curves measured on CEI standard baffle :
 . at 25 cm, normalised 1 m
 . at 1 m for reference
 . Graph amplitude = 60 dB
 (PHL Audio standard)

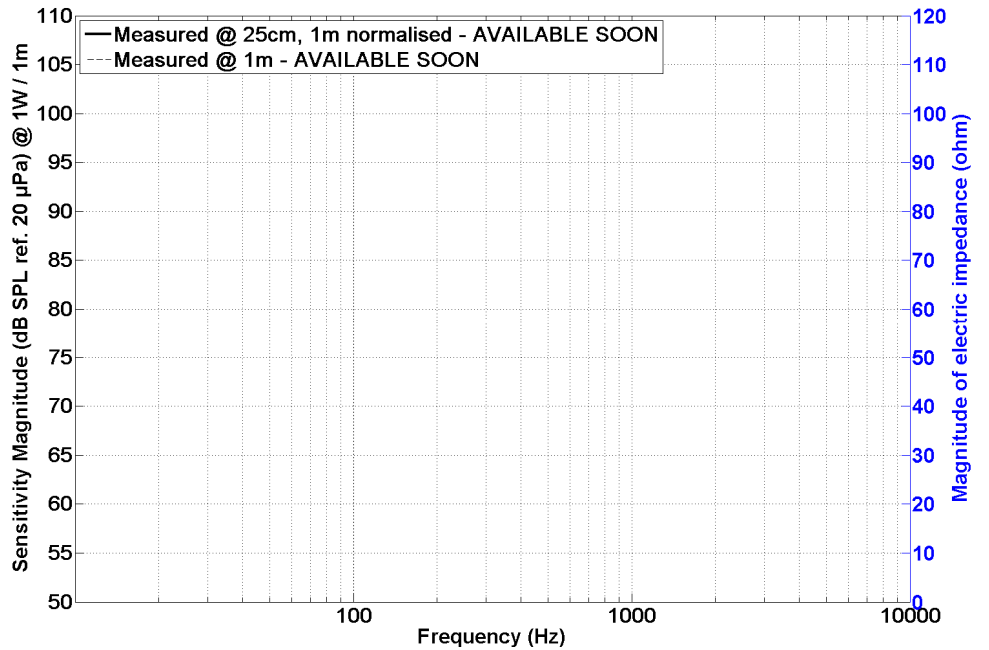

HD curve measured on CEI standard baffle :
 . at 1 meter
 . at power = $P_{AES} / 4$
 . Graph amplitude 0.01 % to 100 %
 (PHL Audio standard for $P_{AES}/4$)

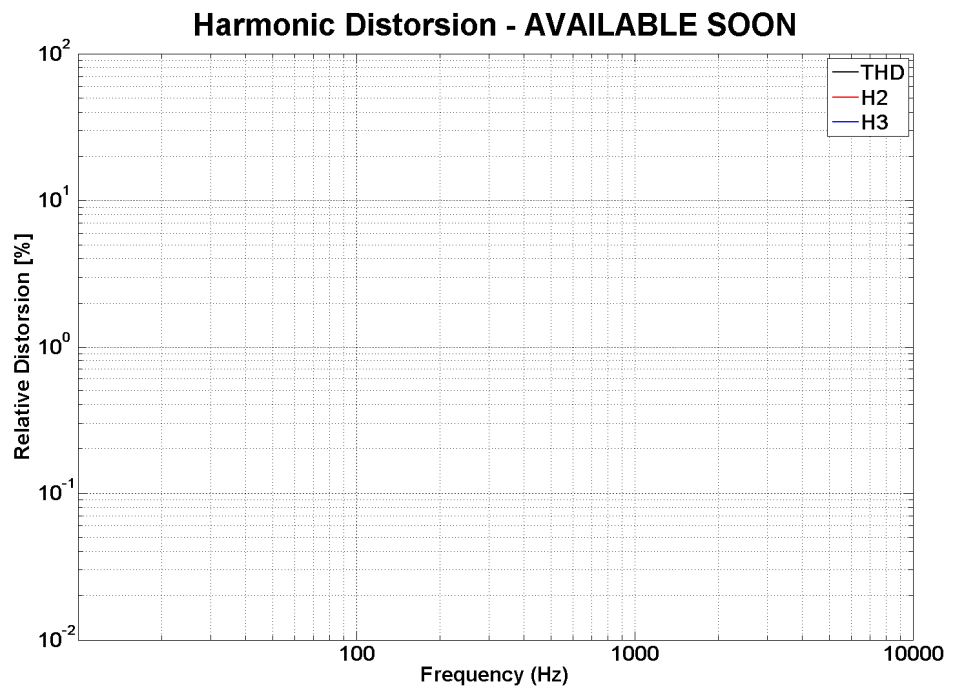

Non linear curves measured thanks to Klippel software and hardware, in free air

