

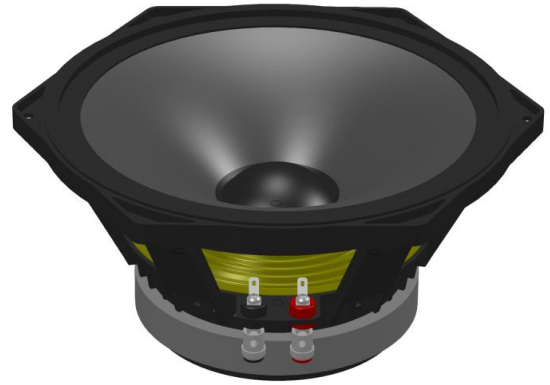

3040

Nominal Diameter	10 " / 25 cm
Rated Impedance	8
Sensitivity	97 dB SPL
Power Handling Capacity	160 W AES
SPL max (continuous)	115 dB SPL
Usable frequency range	150-5000 Hz
Speaker net mass	5 kg

10 inches midrange driver



Architecture highlights :

- Noiseless natural convection Intercooling System
- Single side coated diaphragm
- Ultra light CCAR voice coil
- Midrange unit with critical damping diaphragm

Motor architecture

Magnet material	-	Fe
Voice coil diameter	mm	51
Voice coil length	mm	10
Air gap height	mm	8

Typical characteristics

Rated impedance	Z	Ω	8
Half space sensitivity (1W@1m)	-	dB SPL	97.0
Usable freq. range	-	Hz	150-5000
Power handling capacity (AES)	-	W	160
Max Sound Pressure Level	SPL _{max}	dB SPL	115
Min. impedance modulus	Z _{min}	Ω @Hz	6.6@470
Voice-coil inductance @ 1kHz	Le _{1k}	mH	1.046
Voice-coil inductance @ 10kHz	Le _{10k}	mH	0.476
BL product	BL	N/A	14.3
Moving mass	Mms	kg	0.0300

Thiele-Small parameters

Resonance frequency	Fs	Hz	91 (\pm 19)
DC Resistance	Re	Ω	6 (\pm 0.6)
Mechanical quality factor	Qms	1	3.82
Electrical quality factor	Qes	1	0.51
Total quality factor	Qts	1	0.45
Suspension compliance	Cms	10 ⁻⁶ .m/N	100
Effective piston area	Sd	m ²	0.0377
Equivalent Cas air load	Vas	m ³	0.0204
Max linear excursion	Xmax	mm	\pm 2.0
Linear displacement volume	Vd	10 ⁻³ .m ³	0.0753
Reference efficiency	η_0	%	3.0
Unity load volume	Vas.Qts ²	10 ⁻³ .m ³	4.1

Absolute maximum ratings

Short term max. input voltage	Vmax	V	70
Max.excursion before damage	Xdam	mm	\pm 18.0
Ambient operating temperature	Ta	$^{\circ}$ C	-10 to +50
Storage temperature		$^{\circ}$ C	-20 to +70
Environmental withstanding			Humidity proof

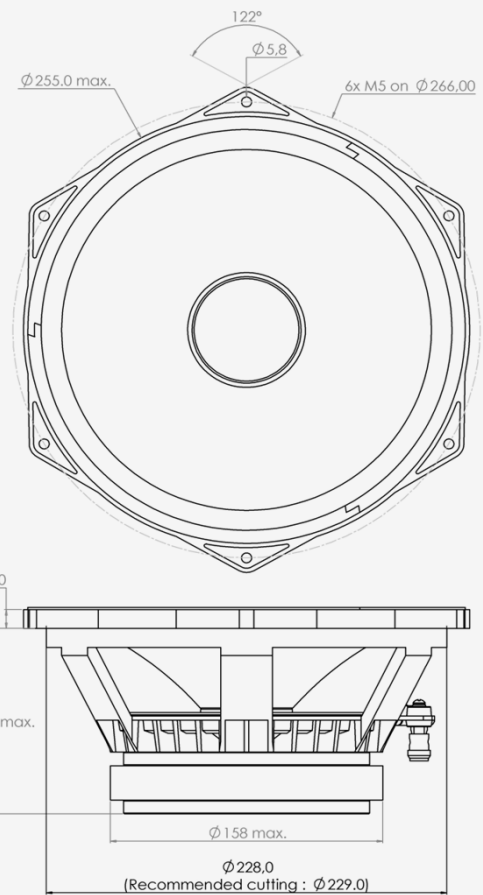

Mounting information

Air volume occupied by the driver	10 ⁻³ .m ³	1.10
Speaker net mass	kg	5.00
Baffle cut-out diameter (front mounting)	mm	229.0
Bolt number & Metric diameter	-	6x M5
Bolt circle diameter	mm	266.0
Max overall dimension (on ears)	mm	283.5
Max overall dimension (out of ears)	mm	254.5
Flange height	mm	11.0
Max magnet diameter	mm	158.0
Max depth (front mounting)	mm	109.0
Recommended reflex box	Lts / Hz	-
Electrical connection		\varnothing 4 mm Push buttons



3040

10 inches midrange driver

SPL curves measured on CEI standard baffle :

- . at 25 cm, normalised 1 m
- . at 1 m for reference
- . Graph amplitude = 60 dB (PHL Audio standard)

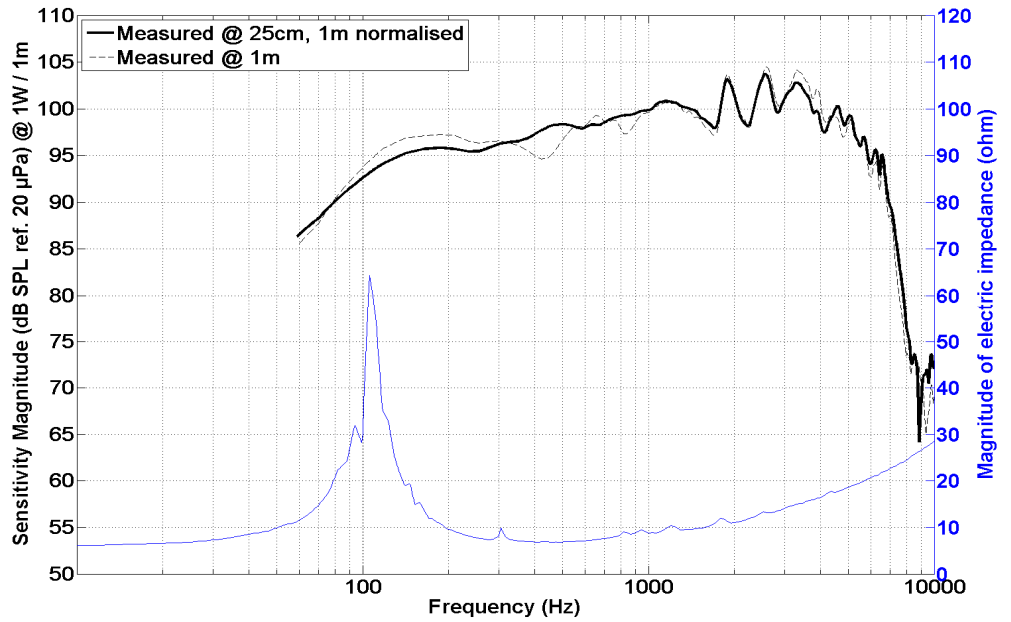

HD curve measured on CEI standard baffle :

- . at 1 meter
- . at power = $P_{AES} / 4$
- . Graph amplitude 0.01 % to 100 % (PHL Audio standard for $P_{AES}/4$)

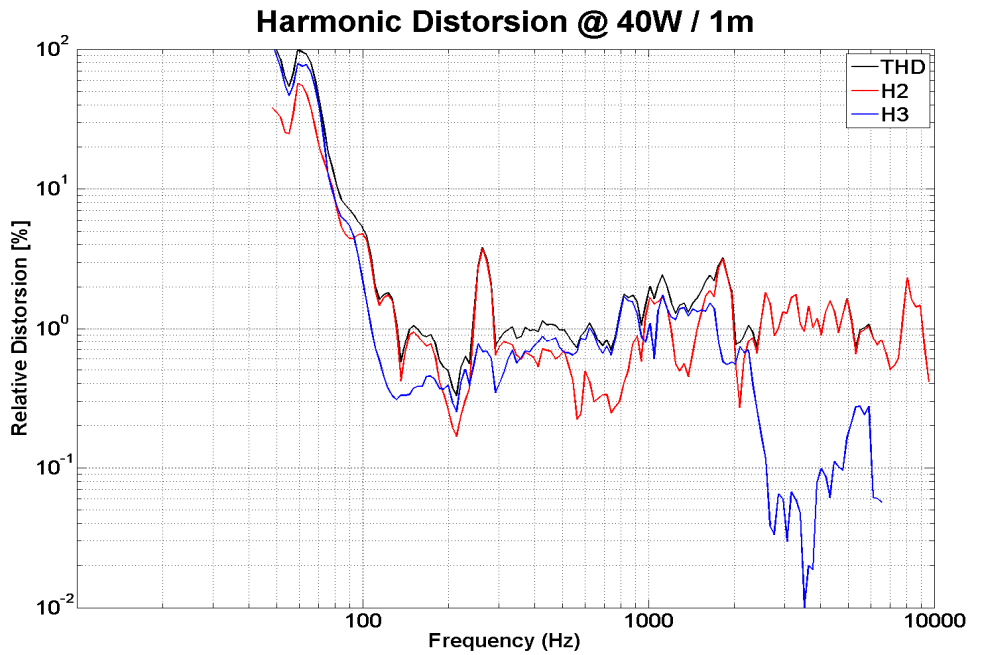

Non linear curves measured thanks to Klippel software and hardware, in free air

