



4071NdU-19

Nominal Diameter	12 " / 30 cm
Rated Impedance	8
Sensitivity	97 dB SPL
Power Handling Capacity	400 W AES
SPL max (continuous)	120 dB SPL
Usable frequency range	50 - 2500 Hz
Speaker net mass	6.5 kg

12" low-mid driver / 1.4" coaxial



Architecture highlights :

- Noiseless Natural Convection Intercooling System
- Front side coated curvilinear cone designed for 2 way systems operation
- Neodymium magnet System with symmetric BL(x) and Le(x) characteristics
- Coaxial apparatus "-19" with 2x M6 on \varnothing 76.2 mm
(Max diameter for HF driver = 142.0 mm)

Motor architecture

Magnet material	-	Nd
Voice coil diameter	mm	77
Voice coil length	mm	17.5
Air gap height	mm	10

Typical characteristics

Rated impedance	Z	Ω	8
Half space sensitivity (1W@1m)	-	dB SPL	97.0
Usable freq. range	-	Hz	50 - 2500
Power handling capacity (AES)	-	W	400
Max Sound Pressure Level	SPL _{max}	dB SPL	120
Min. impedance modulus	Z _{min}	Ω @Hz	6.1@310
Voice-coil inductance @ 1kHz	Le _{1k}	mH	1.286
Voice-coil inductance @ 10kHz	Le _{10k}	mH	0.583
BL product	BL	N/A	23.3
Moving mass	M _{ms}	kg	0.0690

Thiele-Small parameters

Resonance frequency	Fs	Hz	46 (\pm 6)
DC Resistance	Re	Ω	5 (\pm 0.5)
Mechanical quality factor	Q _{ms}	1	4.99
Electrical quality factor	Q _{es}	1	0.18
Total quality factor	Q _{ts}	1	0.18
Suspension compliance	C _{ms}	10 ⁻⁶ .m/N	170
Effective piston area	S _d	m ²	0.0493
Equivalent Cas air load	V _{as}	m ³	0.0597
Max linear excursion	X _{max}	mm	\pm 6.5
Linear displacement volume	V _d	10 ⁻³ .m ³	0.3203
Reference efficiency	η_0	%	3.1
Unity load volume	V _{as} .Q _{ts} ²	10 ⁻³ .m ³	1.9

Absolute maximum ratings

Short term max. input voltage	V _{max}	V	115
Max.excursion before damage	X _{dam}	mm	\pm 16.0
Ambient operating temperature	T _a	$^{\circ}$ C	-10 to +50
Storage temperature		$^{\circ}$ C	-20 to +70
Environmental withstanding			Humidity proof

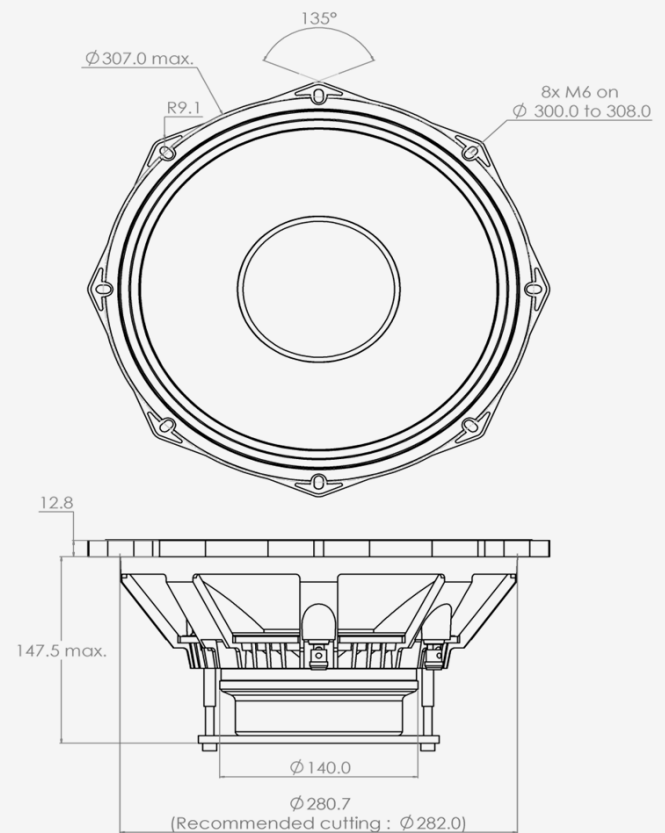

Mounting information

Air volume occupied by the driver	10 ⁻³ .m ³	2.10
Speaker net mass	kg	6.50
Baffle cut-out diameter (front mounting)	mm	282.0
Bolt number & Metric diameter	-	8x M6
Bolt circle diameter	mm	300 to 308
Max overall dimension (on ears)	mm	326.5
Max overall dimension (out of ears)	mm	307.0
Flange height	mm	12.8
Max magnet diameter	mm	140.0
Max depth (front mounting)	mm	141.5
Recommended reflex box	Lts / Hz	-
Electrical connection		\varnothing 4 mm Push buttons



4071NdU-19

12" low-mid driver / 1.4" coaxial

SPL curves measured on CEI standard baffle :

- . at 25 cm, normalised 1 m
- . at 1 m for reference
- . Graph amplitude = 60 dB (PHL Audio standard)



HD curve measured on CEI standard baffle :

- . at 1 meter
- . at power = $P_{AES} / 4$
- . Graph amplitude 0.01 % to 100 % (PHL Audio standard for $P_{AES}/4$)

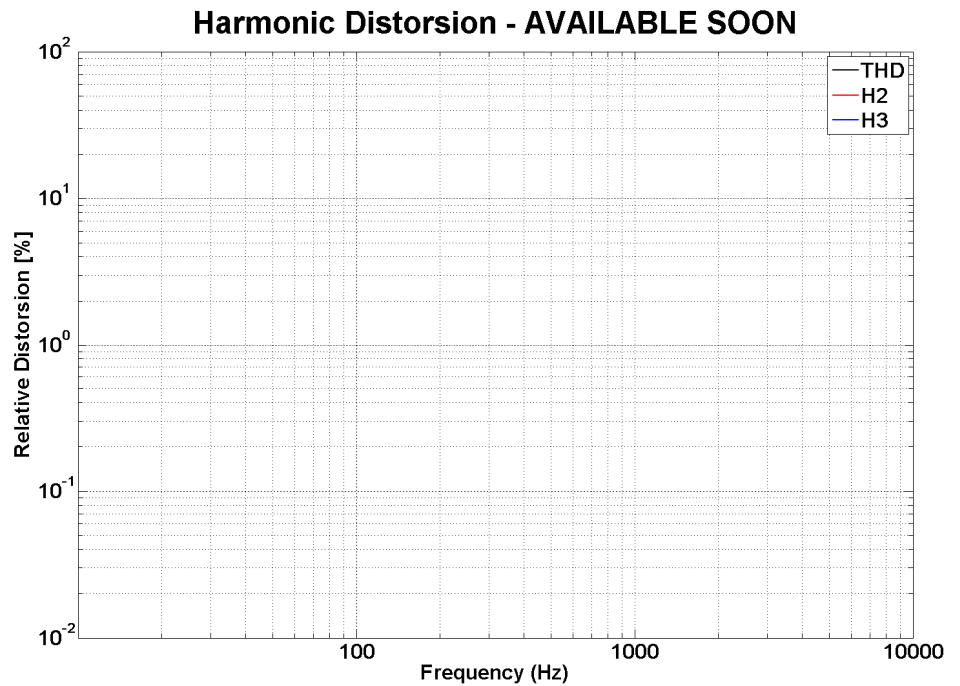

Non linear curves measured thanks to Klippel software and hardware, in free air

