



5241MNdU-7

Nominal Diameter	15" / 38 cm
Rated Impedance	8
Sensitivity	98 dB SPL
Power Handling Capacity	400 W AES
SPL max (continuous)	121 dB SPL
Usable frequency range	50 - 2500 Hz
Speaker net mass	4.9 kg

15" bass driver / 1" coaxial



Architecture highlights :

- Noiseless Natural Convection Intercooling System
- Front side coated curvilinear cone designed for 2 way systems operation
- Neodymium magnet System with symmetric BL(x) and Le(x) characteristics
- Lightweight basket
- Coaxial apparatus "-7" with 3x M6 on \varnothing 57.2 mm and 2x M6 on \varnothing 76.2 mm (Max diameter for HF driver = 95.0 mm)

Motor architecture

Magnet material	-	Nd
Voice coil diameter	mm	77
Voice coil length	mm	20
Air gap height	mm	10

Typical characteristics

Rated impedance	Z	Ω	8
Half space sensitivity (1W@1m)	-	dB SPL	98.0
Usable freq. range	-	Hz	50 - 2500
Power handling capacity (AES)	-	W	400
Max Sound Pressure Level	SPL _{max}	dB SPL	121
Min. impedance modulus	Z _{min}	Ω @Hz	6.7@240
Voice-coil inductance @ 1kHz	Le _{1k}	mH	-
Voice-coil inductance @ 10kHz	Le _{10k}	mH	-
BL product	BL	N/A	24.3
Moving mass	Mms	kg	0.1050

Thiele-Small parameters

Resonance frequency	Fs	Hz	45 (\pm 5)
DC Resistance	Re	Ω	5.6 (\pm 0.6)
Mechanical quality factor	Qms	1	3.71
Electrical quality factor	Qes	1	0.28
Total quality factor	Qts	1	0.26
Suspension compliance	Cms	10 ⁻⁶ .m/N	120
Effective piston area	Sd	m ²	0.0845
Equivalent Cas air load	Vas	m ³	0.1205
Max linear excursion	Xmax	mm	\pm 7.5
Linear displacement volume	Vd	10 ⁻³ .m ³	0.6337
Reference efficiency	η_0	%	3.8
Unity load volume	Vas.Qts ²	10 ⁻³ .m ³	8.3

Absolute maximum ratings

Short term max. input voltage	Vmax	V	115
Max.excursion before damage	Xdam	mm	\pm 16.0
Ambient operating temperature	Ta	$^{\circ}$ C	-10 to +50
Storage temperature		$^{\circ}$ C	-20 to +70
Environmental withstanding			Humidity proof

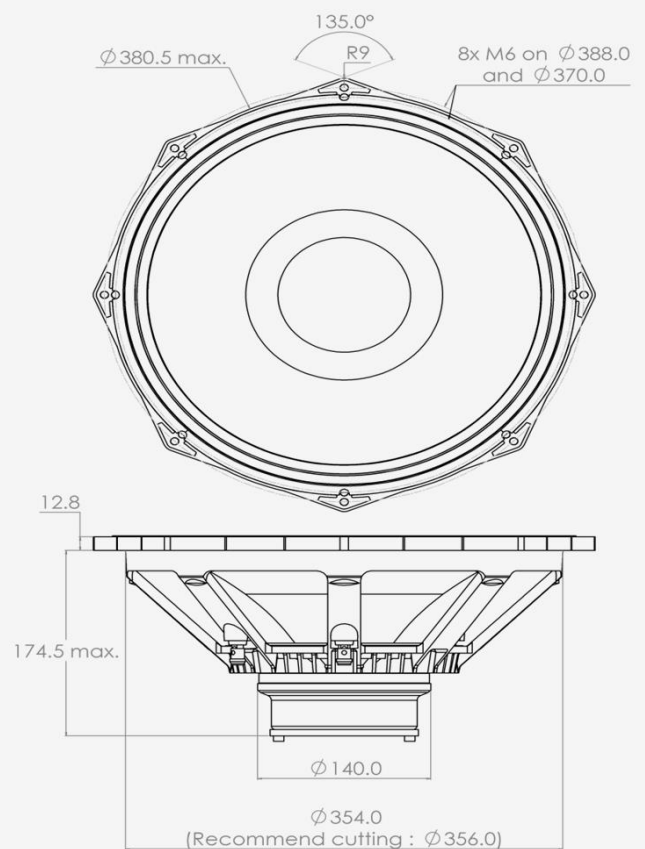

Mounting information

Air volume occupied by the driver	10 ⁻³ .m ³	3.80
Speaker net mass	kg	4.90
Baffle cut-out diameter (front mounting)	mm	356.0
Bolt number & Metric diameter	-	8x M6
Bolt circle diameter	mm	370 & 388
Max overall dimension (on ears)	mm	406.5
Max overall dimension (out of ears)	mm	380.5
Flange height	mm	13.0
Max magnet diameter	mm	140.0
Max depth (front mounting)	mm	174.5
Recommended reflex box	Lts / Hz	-
Electrical connection		\varnothing 4 mm Push buttons



5241MNdU-7

15" bass driver / 1" coaxial

SPL curves measured on CEI standard baffle :

- . at 25 cm, normalised 1 m
- . at 1 m for reference
- . Graph amplitude = 60 dB (PHL Audio standard)

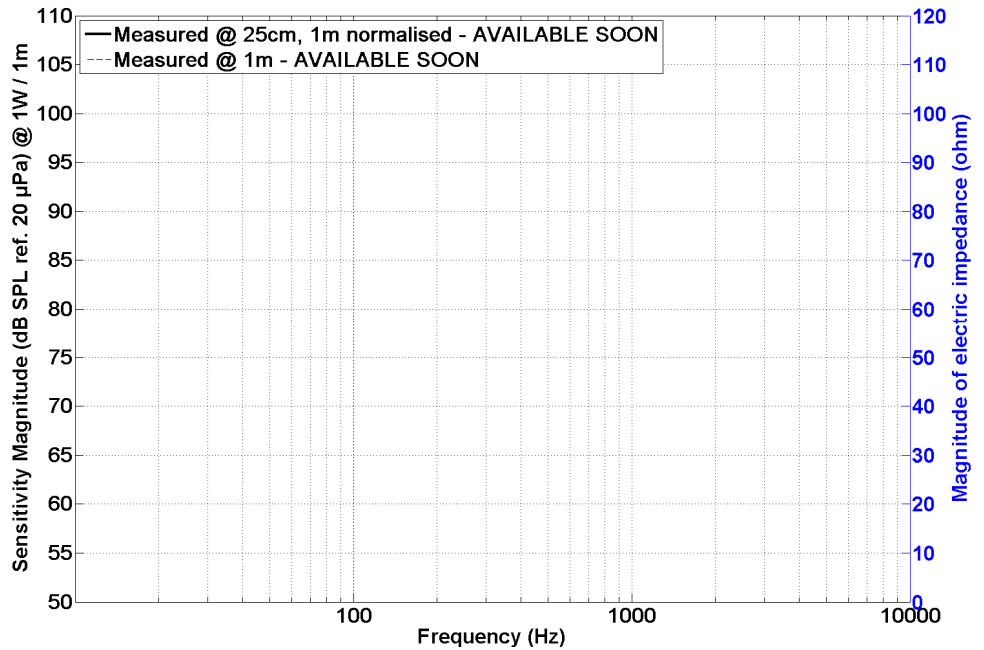

HD curve measured on CEI standard baffle :

- . at 1 meter
- . at power = $P_{AES} / 4$
- . Graph amplitude 0.01 % to 100 % (PHL Audio standard for $P_{AES}/4$)

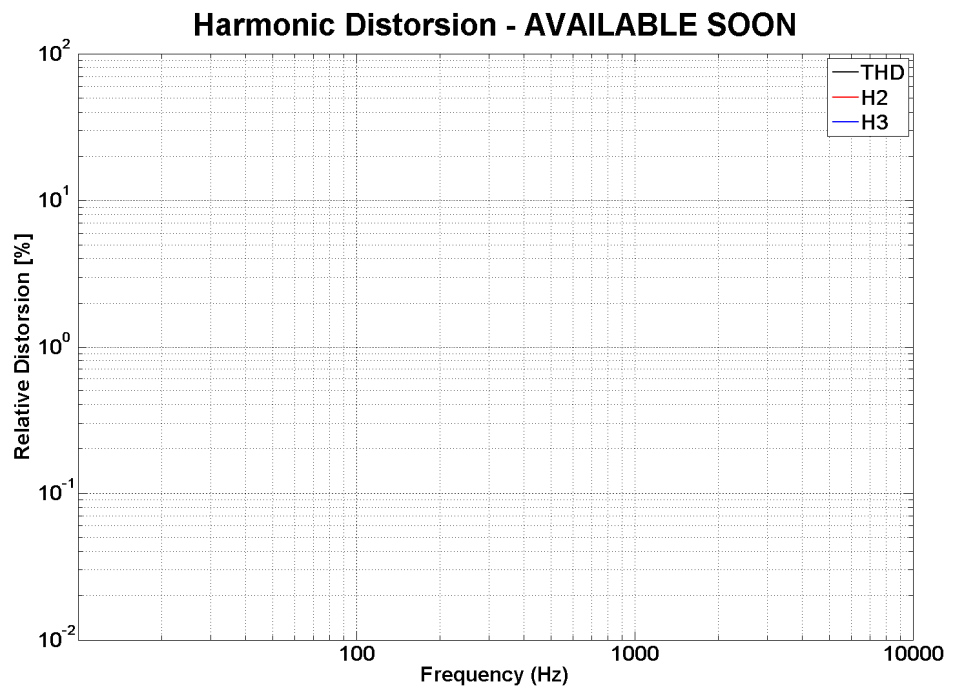

Non linear curves measured thanks to Klippel software and hardware, in free air

