



# 6301MNd

Nominal Diameter	15" / 38 cm
Rated Impedance	8
Sensitivity	95.5 dB SPL
Power Handling Capacity	1300 W AES
SPL max (continuous)	124 dB SPL
Usable frequency range	30 - 1000 Hz
Speaker net mass	5.7 kg

# 15 inches bass driver



### Architecture highlights :

- Ultra light injection molded Magnesium basket
- Neodymium magnet system with symmetric BL(x) and Le(x) characteristics
- Forced-air Intercooling System for low thermal compression
- Heavy duty long excursion suspension with linear behavior for large signal
- Dual side coating diaphragm for excellent sound reproduction and tropical withstand

### Motor architecture

Magnet material	-	Nd
Voice coil diameter	mm	101
Voice coil length	mm	26
Air gap height	mm	10

### Typical characteristics

Rated impedance	Z	Ω	8
Half space sensitivity (1W@1m)	-	dB SPL	95.5
Usable freq. range	-	Hz	30 - 1000
Power handling capacity (AES)	-	W	1300
Max Sound Pressure Level	SPL <sub>max</sub>	dB SPL	124
Min. impedance modulus	Z <sub>min</sub>	Ω@Hz	6.6@210
Voice-coil inductance @ 1kHz	Le <sub>1k</sub>	mH	1.616
Voice-coil inductance @ 10kHz	Le <sub>10k</sub>	mH	1.111
BL product	BL	N/A	25.5
Moving mass	Mms	kg	0.1500

### Thiele-Small parameters

Resonance frequency	Fs	Hz	36 (±5)
DC Resistance	Re	Ω	5.4 (±0.5)
Mechanical quality factor	Qms	1	3.39
Electrical quality factor	Qes	1	0.28
Total quality factor	Qts	1	0.26
Suspension compliance	Cms	10 <sup>-6</sup> .m/N	130
Effective piston area	Sd	m <sup>2</sup>	0.0871
Equivalent Cas air load	Vas	m <sup>3</sup>	0.1400
Max linear excursion	Xmax	mm	± 10.5
Linear displacement volume	Vd	10 <sup>-3</sup> .m <sup>3</sup>	0.9145
Reference efficiency	η <sub>0</sub>	%	2.3
Unity load volume	Vas.Qts <sup>2</sup>	10 <sup>-3</sup> .m <sup>3</sup>	9.5

### Absolute maximum ratings

Short term max. input voltage	Vmax	V	205
Max.excursion before damage	Xdam	mm	± 19.0
Ambient operating temperature	Ta	°C	-10 to +50
Storage temperature		°C	-20 to +70
Environmental withstanding			Tropical

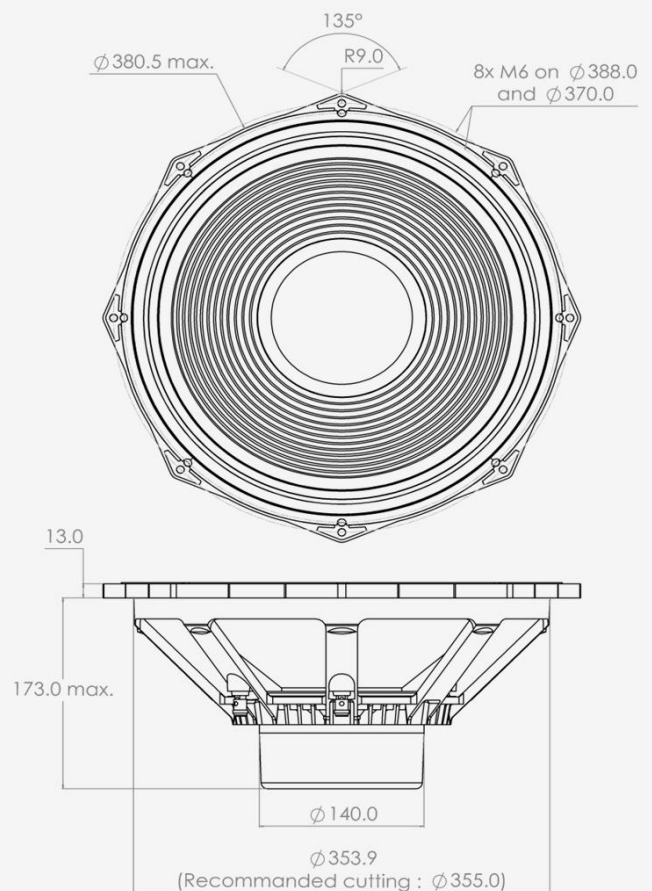

### Mounting information

Air volume occupied by the driver	10 <sup>-3</sup> .m <sup>3</sup>	4.20
Speaker net mass	kg	5.70
Baffle cut-out diameter (front mounting)	mm	355.0
Bolt number & Metric diameter	-	8x M6
Bolt circle diameter	mm	370 and 388
Max overall dimension (on ears)	mm	406.5
Max overall dimension (out of ears)	mm	380.5
Flange height	mm	13.0
Max magnet diameter	mm	140.0
Max depth (front mounting)	mm	173.0
Recommended reflex box	Lts / Hz	-
Electrical connection		Ø4 mm Push buttons



# 6301MNd

# 15 inches bass driver

SPL curves measured on CEI standard baffle :

- . at 25 cm, normalised 1 m
- . at 1 m for reference
- . Graph amplitude = 60 dB (PHL Audio standard)



HD curve measured on CEI standard baffle :

- . at 1 meter
- . at power =  $P_{AES} / 4$
- . Graph amplitude 0.01 % to 100 % (PHL Audio standard for  $P_{AES}/4$ )

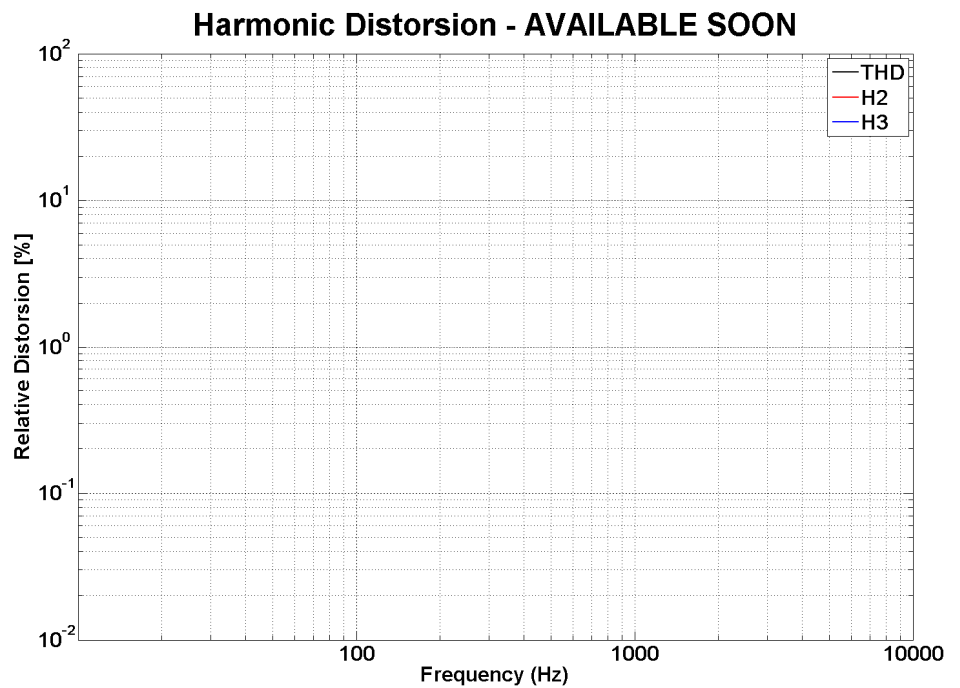

Non linear curves measured thanks to Klippel software and hardware, in free air

