



7081

Nominal Diameter	18" / 46 cm
Rated Impedance	8
Sensitivity	96 dB SPL
Power Handling Capacity	750 W AES
SPL max (continuous)	121 dB SPL
Usable frequency range	30 - 800 Hz
Speaker net mass	10.9 kg

18 inches bass driver



Architecture highlights :

- Forced-air Intercooling System for low thermal compression
- Single side coated Curvilinear cone (Humidity proof withstanding)
- High compliance double half-roll fabric surround

Motor architecture

Magnet material	-	Fe
Voice coil diameter	mm	101
Voice coil length	mm	22
Air gap height	mm	10

Typical characteristics

Rated impedance	Z	Ω	8
Half space sensitivity (1W@1m)	-	dB SPL	96.0
Usable freq. range	-	Hz	30 - 800
Power handling capacity (AES)	-	W	750
Max Sound Pressure Level	SPL _{max}	dB SPL	121
Min. impedance modulus	Z _{min}	Ω @Hz	6.7@200
Voice-coil inductance @ 1kHz	Le _{1k}	mH	1.414
Voice-coil inductance @ 10kHz	Le _{10k}	mH	0.606
BL product	BL	N/A	22.7
Moving mass	Mms	kg	0.1900

Thiele-Small parameters

Resonance frequency	Fs	Hz	34 (± 5)
DC Resistance	Re	Ω	5.6 (± 0.6)
Mechanical quality factor	Qms	1	5.81
Electrical quality factor	Qes	1	0.44
Total quality factor	Qts	1	0.41
Suspension compliance	Cms	10 ⁻⁶ .m/N	110
Effective piston area	Sd	m ²	0.1282
Equivalent Cas air load	Vas	m ³	0.2676
Max linear excursion	Xmax	mm	± 7.5
Linear displacement volume	Vd	10 ⁻³ .m ³	0.9614
Reference efficiency	η_0	%	2.3
Unity load volume	Vas.Qts ²	10 ⁻³ .m ³	45.1

Absolute maximum ratings

Short term max. input voltage	Vmax	V	155
Max.excursion before damage	Xdam	mm	± 16.0
Ambient operating temperature	Ta	$^{\circ}$ C	-10 to +50
Storage temperature		$^{\circ}$ C	-20 to +70
Environmental withstanding			Humidity proof

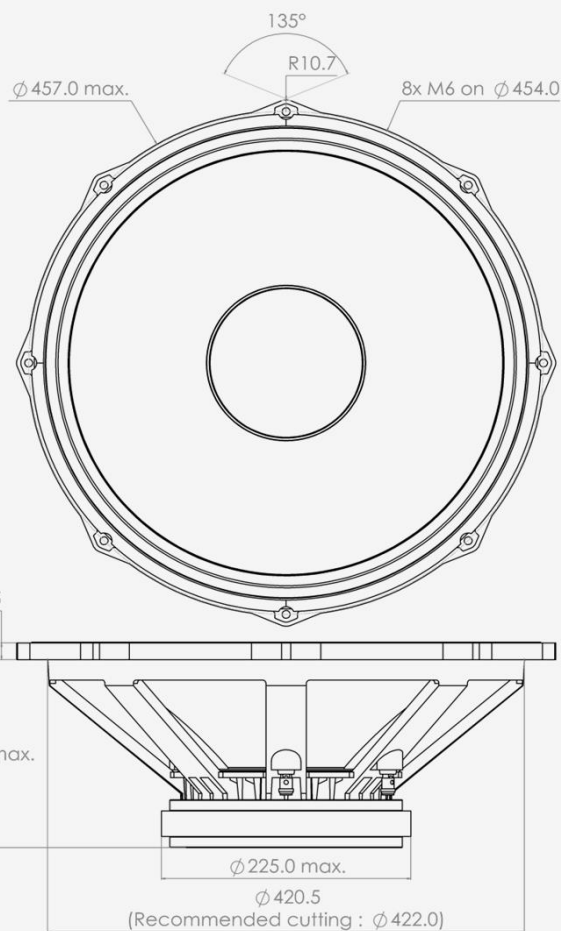

Mounting information

Air volume occupied by the driver	10 ⁻³ .m ³	7.00
Speaker net mass	kg	10.90
Baffle cut-out diameter (front mounting)	mm	422.0
Bolt number & Metric diameter	-	8x M6
Bolt circle diameter	mm	454.0
Max overall dimension (on ears)	mm	476.0
Max overall dimension (out of ears)	mm	457.0
Flange height	mm	15.0
Max magnet diameter	mm	225.0
Max depth (front mounting)	mm	171.0
Recommended reflex box	Lts / Hz	-
Electrical connection		\varnothing 4 mm Push buttons



7081

18 inches bass driver

SPL curves measured on CEI standard baffle :

- . at 25 cm, normalised 1 m
- . at 1 m for reference
- . Graph amplitude = 60 dB (PHL Audio standard)

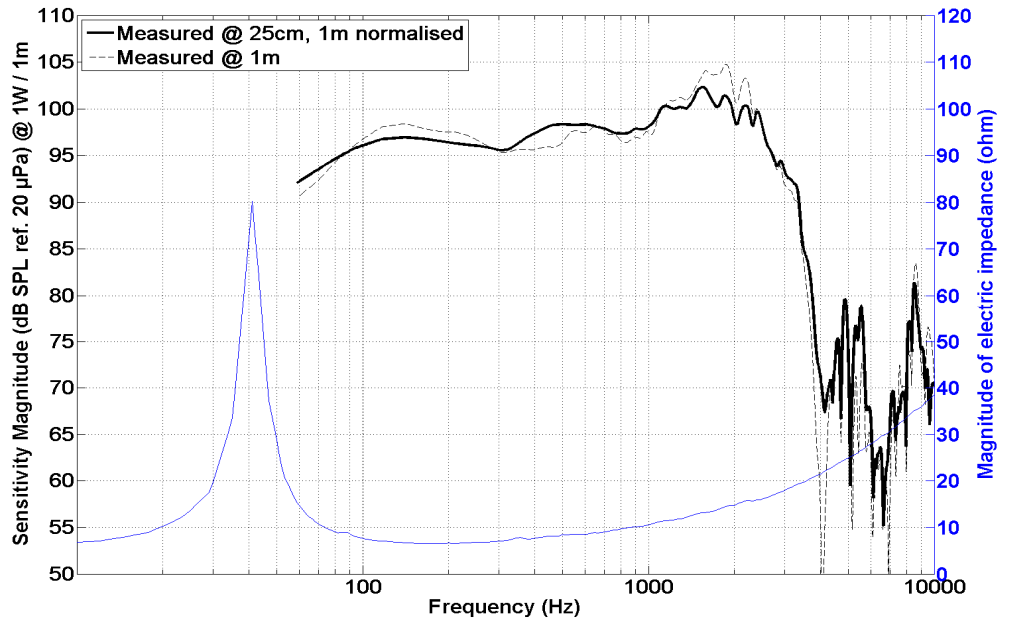

HD curve measured on CEI standard baffle :

- . at 1 meter
- . at power = $P_{AES} / 4$
- . Graph amplitude 0.01 % to 100 % (PHL Audio standard for $P_{AES}/4$)

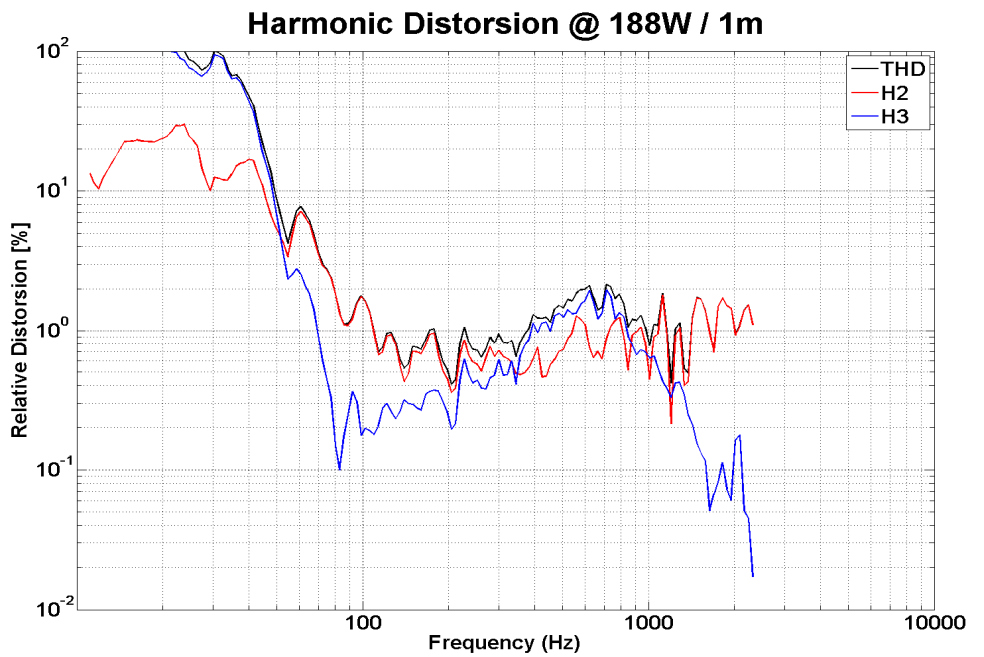

Non linear curves measured thanks to Klippel software and hardware, in free air

Force factor $Bl(x)$

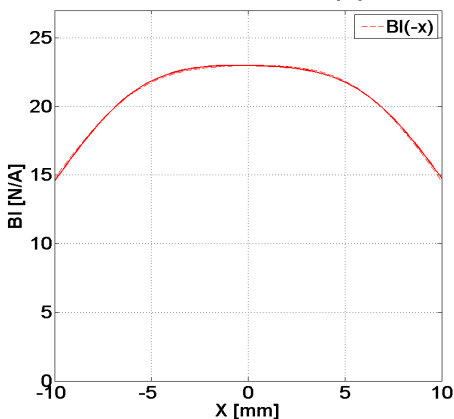

Stiffness of suspension $Kms(X)$

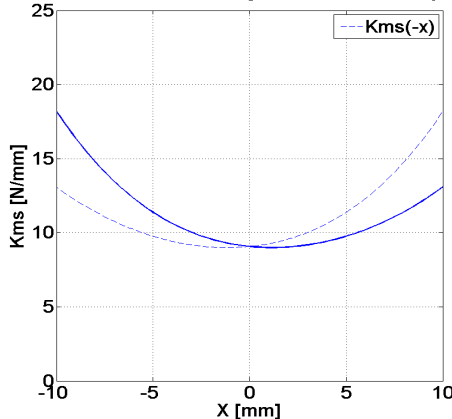

Electrical inductance $L(X,I=0)$

