



7321Nd

Nominal Diameter	18" / 46 cm
Rated Impedance	8
Sensitivity	96.5 dB SPL
Power Handling Capacity	1200 W AES
SPL max (continuous)	124 dB SPL
Usable frequency range	25 - 800 Hz
Speaker net mass	7.4 kg

18 inches bass driver



Architecture highlights :

- Forced-air Intercooling System for low thermal compression
- Neodymium magnet system with symmetric $BL(x)$ and $Le(x)$ characteristics
- Both sides coated curvilinear cone (Tropical withstanding)
- Heavy duty long excursion suspension with linear behavior for large signal

Motor architecture

Magnet material	-	Nd
Voice coil diameter	mm	101
Voice coil length	mm	25
Air gap height	mm	10

Typical characteristics

Rated impedance	Z	Ω	8
Half space sensitivity (1W@1m)	-	dB SPL	96.5
Usable freq. range	-	Hz	25 - 800
Power handling capacity (AES)	-	W	1200
Max Sound Pressure Level	SPL _{max}	dB SPL	124
Min. impedance modulus	Z _{min}	Ω @Hz	6.6@190
Voice-coil inductance @ 1kHz	Le _{1k}	mH	1.914
Voice-coil inductance @ 10kHz	Le _{10k}	mH	0.839
BL product	BL	N/A	28.0
Moving mass	Mms	kg	0.217

Thiele-Small parameters

Resonance frequency	Fs	Hz	34 (± 5)
DC Resistance	Re	Ω	5.2 (± 0.5)
Mechanical quality factor	Qms	1	3.86
Electrical quality factor	Qes	1	0.31
Total quality factor	Qts	1	0.28
Suspension compliance	Cms	10^{-6} .m/N	100
Effective piston area	Sd	m ²	0.1250
Equivalent Cas air load	Vas	m ³	0.2210
Max linear excursion	Xmax	mm	± 10.0
Linear displacement volume	Vd	10^{-3} .m ³	1.2504
Reference efficiency	η_0	%	2.7
Unity load volume	Vas.Qts ²	10^{-3} .m ³	17.9

Absolute maximum ratings

Short term max. input voltage	Vmax	V	195
Max.excursion before damage	Xdam	mm	± 21.0
Ambient operating temperature	Ta	$^{\circ}$ C	-10 to +50
Storage temperature		$^{\circ}$ C	-20 to +70
Environmental withstanding			Tropical

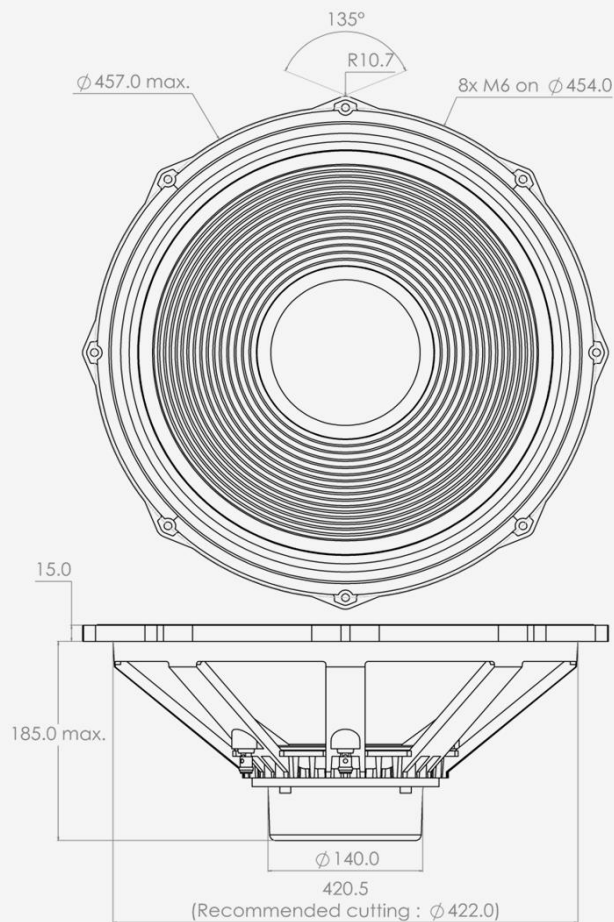

Mounting information

Air volume occupied by the driver	10^{-3} .m ³	6.20
Speaker net mass	kg	7.4
Baffle cut-out diameter (front mounting)	mm	422.0
Bolt number & Metric diameter	-	8x M6
Bolt circle diameter	mm	454.0
Max overall dimension (on ears)	mm	476.0
Max overall dimension (out of ears)	mm	457.0
Flange height	mm	15.0
Max magnet diameter	mm	140.0
Max depth (front mounting)	mm	185.0
Recommended reflex box	Lts / Hz	180L / 35Hz
Electrical connection		$\varnothing 4$ mm Push buttons



7321Nd

18 inches bass driver

SPL curves measured on CEI standard baffle :

- . at 25 cm, normalised 1 m
- . at 1 m for reference
- . Graph amplitude = 60 dB (PHL Audio standard)

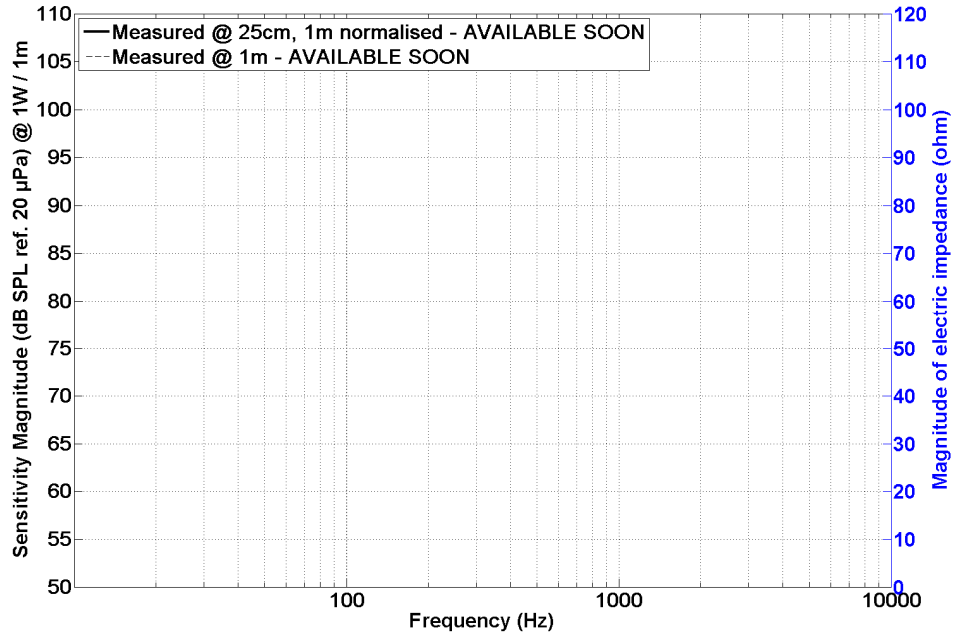

HD curve measured on CEI standard baffle :

- . at 1 meter
- . at power = $P_{AES} / 4$
- . Graph amplitude 0.01 % to 100 % (PHL Audio standard for $P_{AES}/4$)

#REF!
#REF!
#REF!

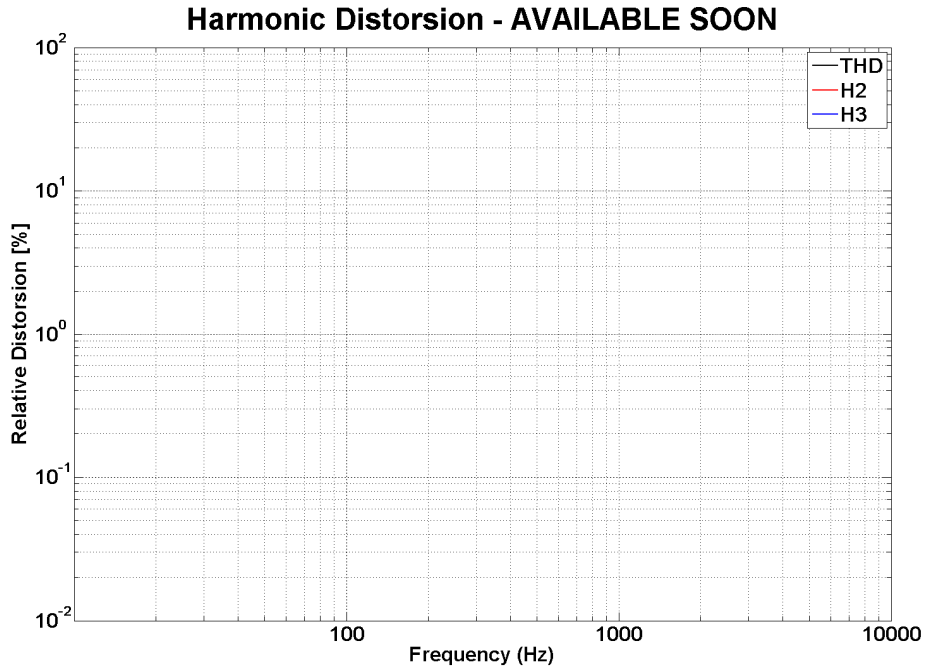

Non linear curves measured thanks to Klippel software and hardware, in free air

