



900Nd

Nominal Diameter	5" / 13 cm
Rated Impedance	8
Sensitivity	90 dB SPL
Power Handling Capacity	120 W AES
SPL max (continuous)	108 dB SPL
Usable frequency range	60 - 3000 Hz
Speaker net mass	0.98 kg

5 inches low-mid driver



Architecture highlights :

- Noiseless natural convection Intercooling System
- Neodymium magnet system with symmetric BL(x) and Le(x)
- Long excursion suspension with linear behavior for large signal
- Lightweight basket

Motor architecture

Magnet material	-	Nd
Voice coil diameter	mm	38
Voice coil length	mm	16
Air gap height	mm	6

Typical characteristics

Rated impedance	Z	Ω	8
Half space sensitivity (1W@1m)	-	dB SPL	90.0
Usable freq. range	-	Hz	60 - 3000
Power handling capacity (AES)	-	W	120
Max Sound Pressure Level	SPL _{max}	dB SPL	108
Min. impedance modulus	Z _{min}	Ω @Hz	6.3@500
Voice-coil inductance @ 1kHz	Le _{1k}	mH	0.619
Voice-coil inductance @ 10kHz	Le _{10k}	mH	0.223
BL product	BL	N/A	8.1
Moving mass	Mms	kg	0.0112

Thiele-Small parameters

Resonance frequency	Fs	Hz	65 (± 10)
DC Resistance	Re	Ω	5.7 (± 0.6)
Mechanical quality factor	Qms	1	3.81
Electrical quality factor	Qes	1	0.40
Total quality factor	Qts	1	0.36
Suspension compliance	Cms	10 ⁻⁶ .m/N	540
Effective piston area	Sd	m ²	0.0102
Equivalent Cas air load	Vas	m ³	0.0078
Max linear excursion	Xmax	mm	± 6.5
Linear displacement volume	Vd	10 ⁻³ .m ³	0.0663
Reference efficiency	η_0	%	0.5
Unity load volume	Vas.Qts ²	10 ⁻³ .m ³	1.0

Absolute maximum ratings

Short term max. input voltage	Vmax	V	60
Max.excursion before damage	Xdam	mm	± 12
Ambient operating temperature	Ta	$^{\circ}\text{C}$	-10 to +50
Storage temperature		$^{\circ}\text{C}$	-20 to +70
Environmental withstanding			Tropical

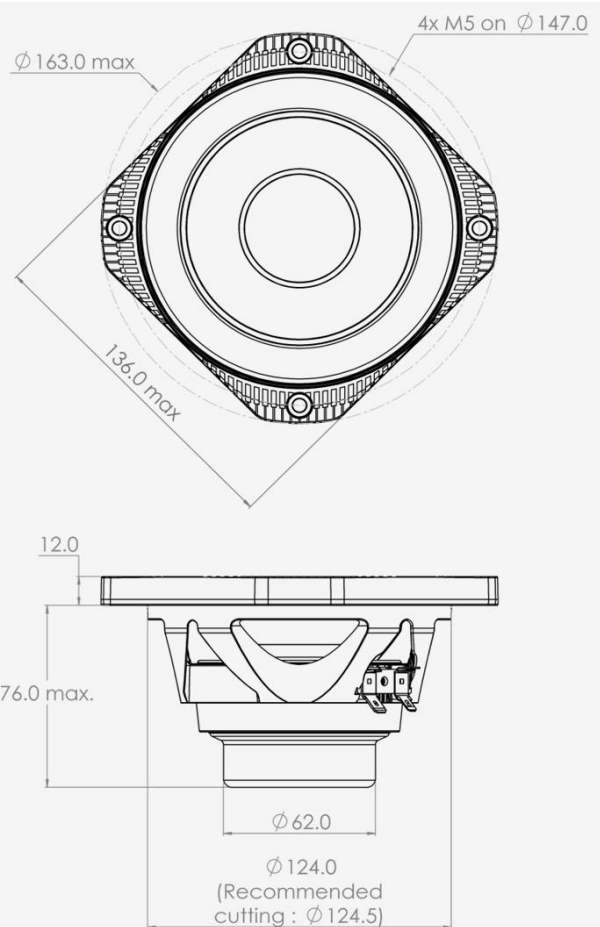

Mounting information

Air volume occupied by the driver	10 ⁻³ .m ³	0.18
Speaker net mass	kg	0.98
Baffle cut-out diameter (front mounting)	mm	124.5
Bolt number & Metric diameter	-	4x M5
Bolt circle diameter	mm	147.0
Max overall dimension (on ears)	mm	163.0
Max overall dimension (out of ears)	mm	136.0
Flange height	mm	12.0
Max magnet diameter	mm	-
Max depth (front mounting)	mm	76.0
Recommended reflex box	Lts / Hz	-
Electrical connection		6.35x0.8 + 4.8x0.5 FASTON



900Nd

5 inches low-mid driver

SPL curves measured on CEI standard baffle :

- . at 25 cm, normalised 1 m
- . at 1 m for reference
- . Graph amplitude = 60 dB (PHL Audio standard)

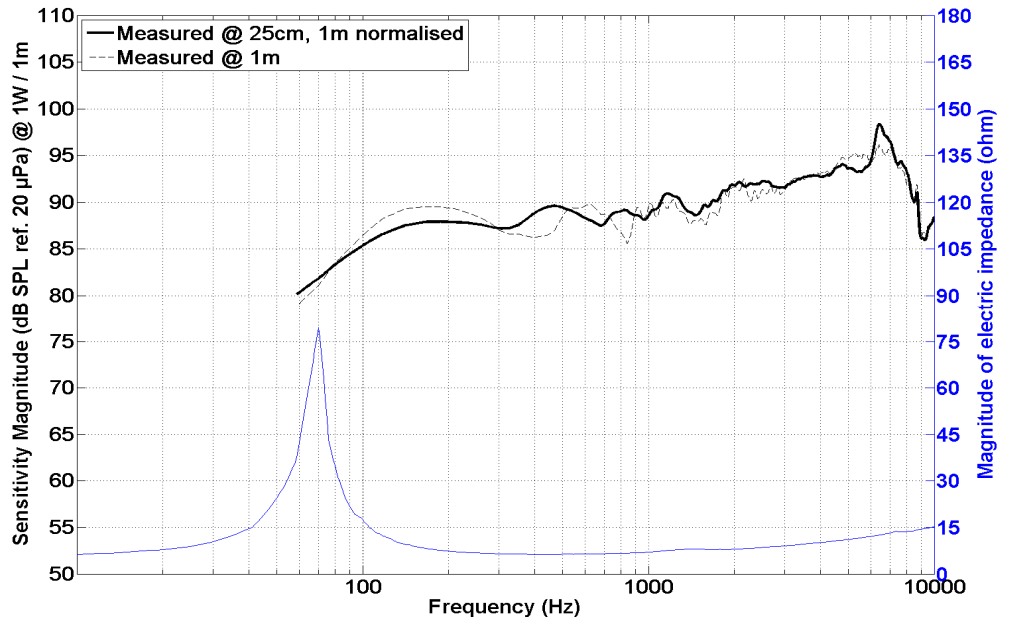

HD curve measured on CEI standard baffle :

- . at 1 meter
- . at power = $P_{AES} / 4$
- . Graph amplitude 0.01 % to 100 % (PHL Audio standard for $P_{AES}/4$)

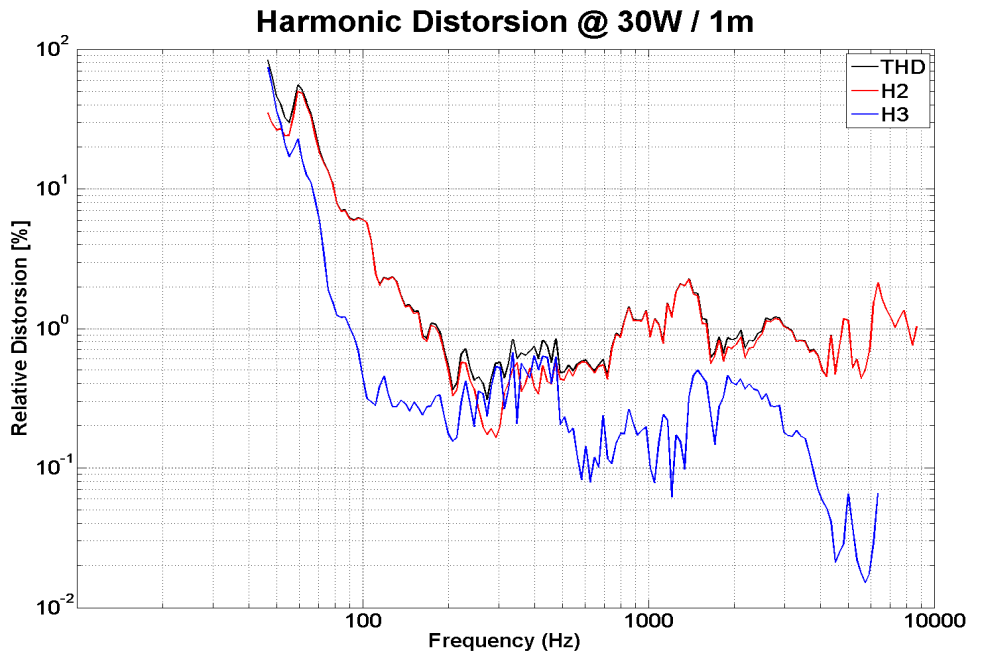

Non linear curves measured thanks to Klippel software and hardware, in free air

